

Guincho com motor a ar G050
Tipo G050 0MP5-01 Comando manual acoplado

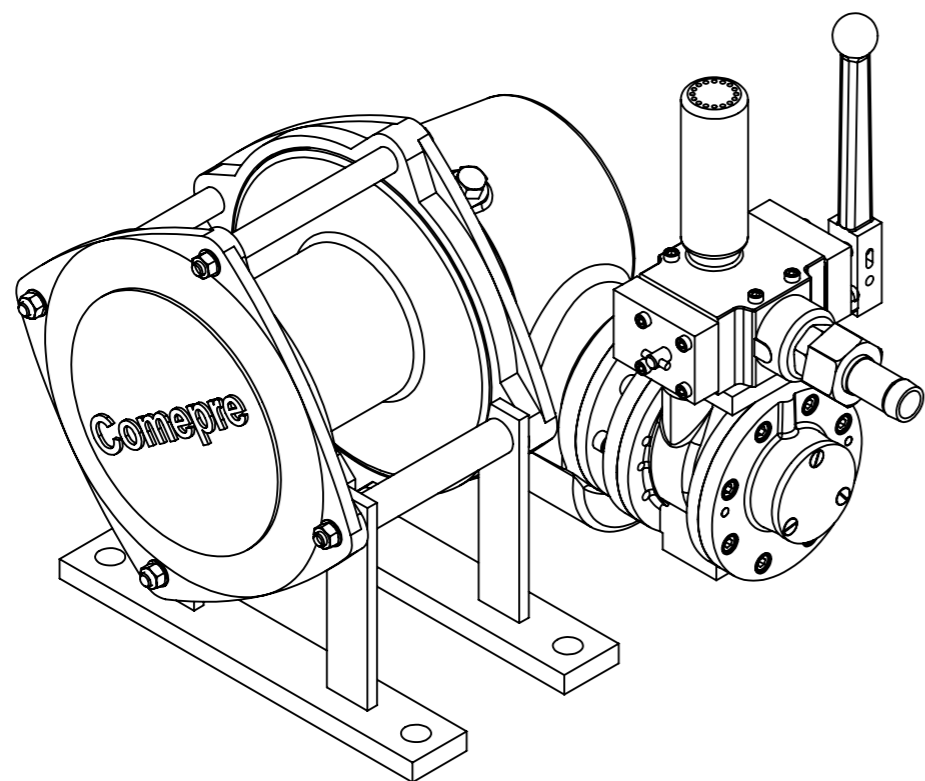

Guincho com motor a ar G050
Tipo G050 0MP5-03 comando manual a distancia

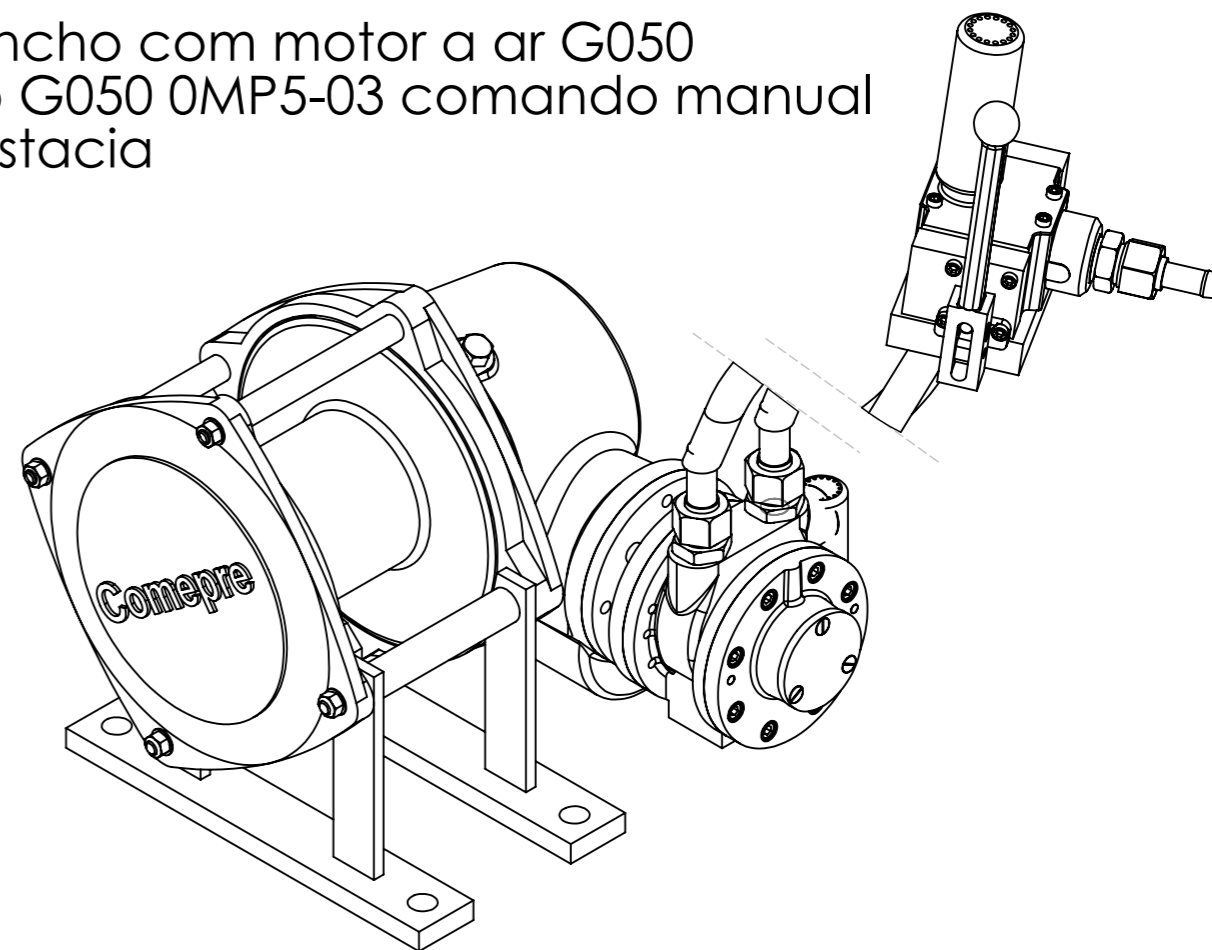

Guincho de tambor duplo com motor a ar G050
Tipo G050 0MP5-11 comando manual acoplado

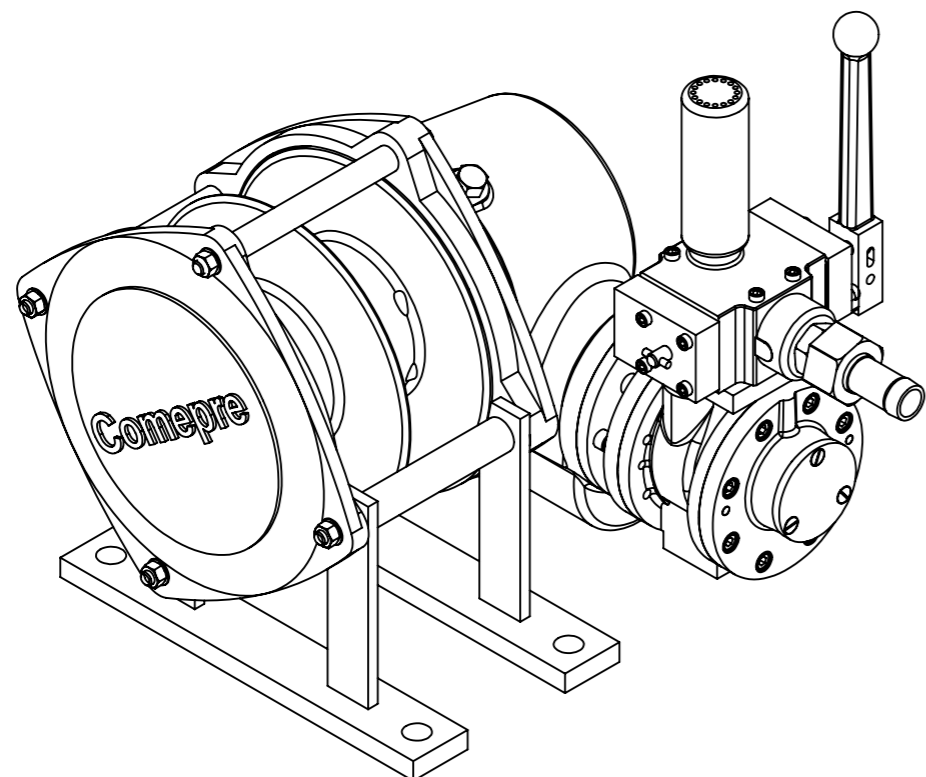

Guincho com motor a ar G050
Tipo G050 0MP5-02 com dispositivo manual acoplado. (Na falta de ar, usar manivela)

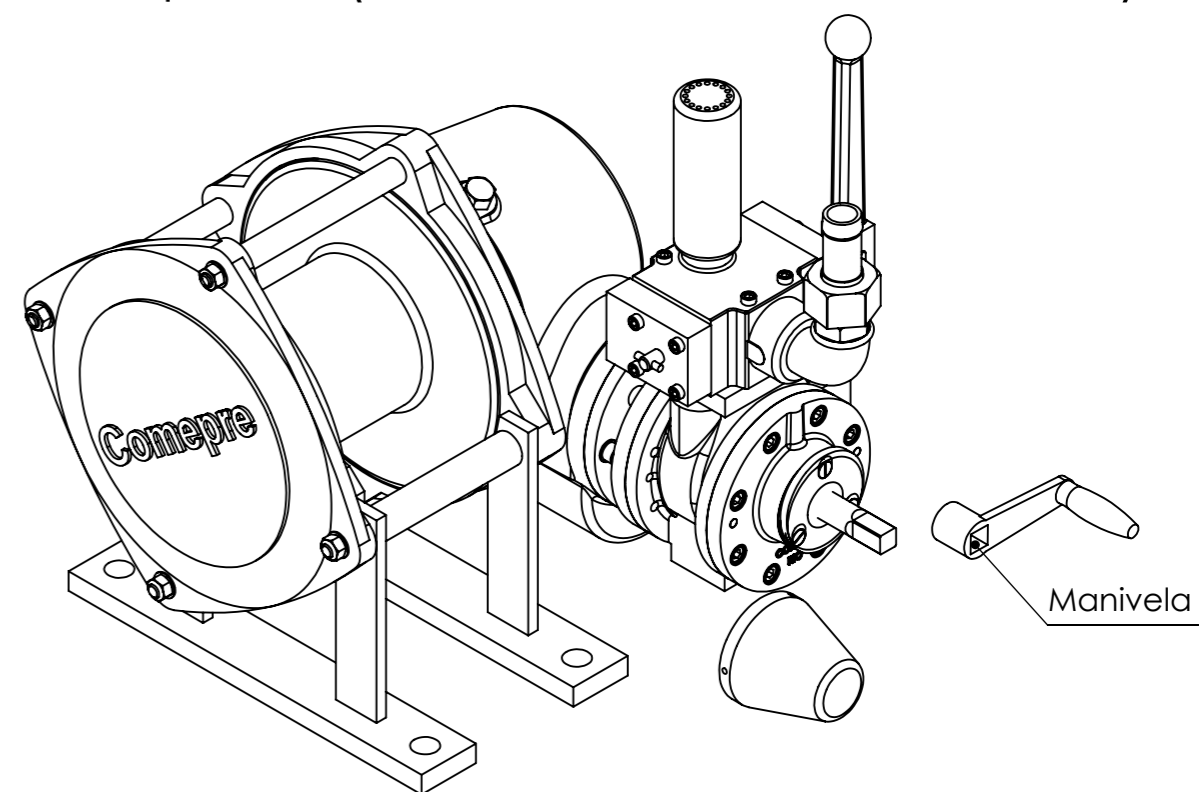

Guincho com motor a ar G050

Tipo G050 OMP5-01

Guincho pneumático COMEPRE de baixo peso, com motor de palheta e válvula de comando retornável (com ponto neutro) e sistema de redução sem-fim auto-frenante.

Lubrificantes indicados:

- ISO VG 680 - para temperatura de 0°C à +40°C
Ex.: TEXACO MEROPA 680, SHELL OMALA 680

Capacidade de carga	500 kg
Velocidade do cabo	10 - 16 M/min
Ø nominal do cabo	¼"
Comprimento do cabo	95 M
Pressão do ar	7 BAR
Consumo de ar	50 L/s
Peso aproximado	68 kg

